

Longwood Place Phase One

March 11, 2026



Planning Department

CITY of BOSTON

ZOOM TIPS AND MEETING INFO

- We will be recording this meeting and posting it on the Planning Department's project webpage
- Use raise hand function (dial *9 if joining by phone) to be invited to unmute (dial *6 if joining by phone) to ask your question or provide comment
- You can also add your questions or comments in the chat.



Mute/ unmute yourself



Turn your camera on/ off



Access zoom polls



Show live captions

CC

Raise hand, wait for your turn



MEETING INFORMATION

- The presentation for this evening is available to view on the project webpage on the Planning Department website (link available in chat)
- Meeting recording will be uploaded to the project webpage within 48 hours
- Comments may be submitted through the project webpage or emailed directly to sarah.peck@boston.gov

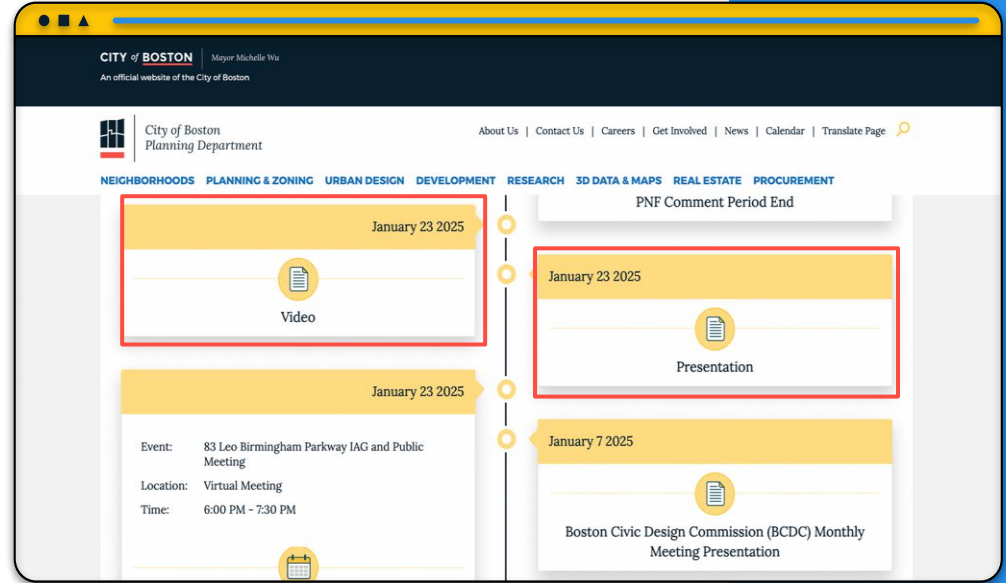

The comment period is open through April 1, 2026



Help Us Understand Who We Are Joined By Today

INTRO POLL

If you can't get the poll to work, feel free to type your responses in the chat

1. Have you engaged on an Article 80 project before today?
2. What is your housing situation?
3. What is your connection to this project?



AGENDA

1

Introduction

2

Project Presentation

3

Questions & Answers



MEETING CODE OF CONDUCT



Respect one Another

All attendees are expected to respect one another and any differences of opinion

Welcome Difference in Opinion



We welcome differences of opinion, including opinions that differ from the Planning Dept



Constructive Feedback

Constructive comments and opinions should be aimed at topics, not people

Allow All to Speak



To allow your fellow attendees a chance to ask their questions or comments, speaking time will be limited to 2 minutes

Code of Conduct



HELP US IMPROVE OUR PUBLIC MEETINGS

We want to hear about your experience during our meeting today so that we can make our public meetings better.

Please **fill out this feedback form** after the meeting to help us improve our engagement!



FEEDBACK FORM

LONGWOOD PLACE

PUBLIC MEETING

MARCH 11, 2026

SKANSKA

SASAKI

PICKARD CHILTON

KPF

Jacobs

ELKUS | MANFREDI
ARCHITECTS

Agenda

-
- 1. Project Overview**
 - 2. SID Overview**
 - 3. Public Realm & Open Space**
 - 4. Building Design**
 - 5. Summary of Public Benefits**
 - 6. Discussion**

1

Project Overview

Project Schedule

LONGWOOD
PLACE

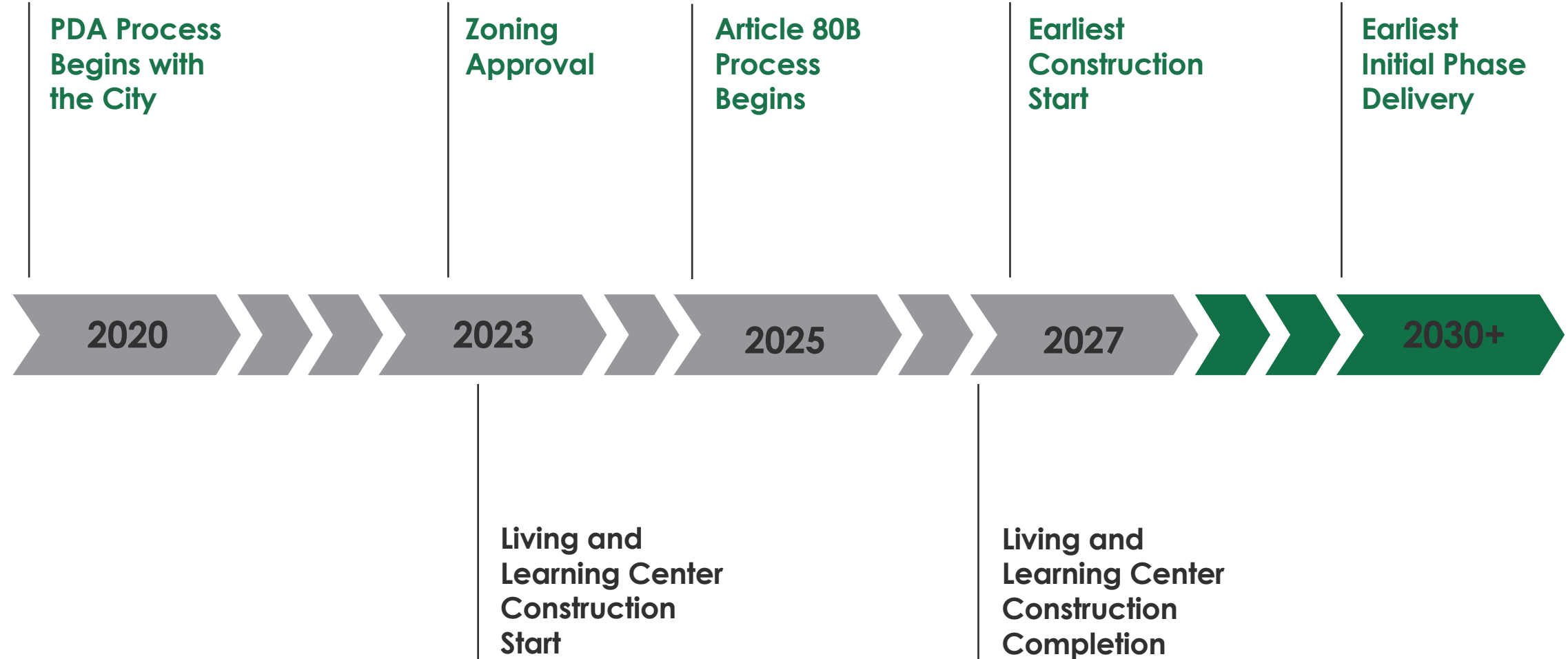

Simmons
UNIVERSITY

Article 80B Project Timeline

PDA – 2022

ARTICLE 80B – 2025-2026



Project Goals

- › **Add** significant new publicly accessible **open space** to the LMA.
- › **Invite the public** into—and through—the site for the first time in decades.
- › **Create housing** and neighborhood amenities.
- › **Design sustainable buildings** with both harmonious and distinct architectural character.
- › Optimize building sizes to **minimize shadow** and **support continued innovation** and progress in the LMA.
- › Further expand and **enhance public realm** with ground floor retail and community spaces.



LMA Neighborhood

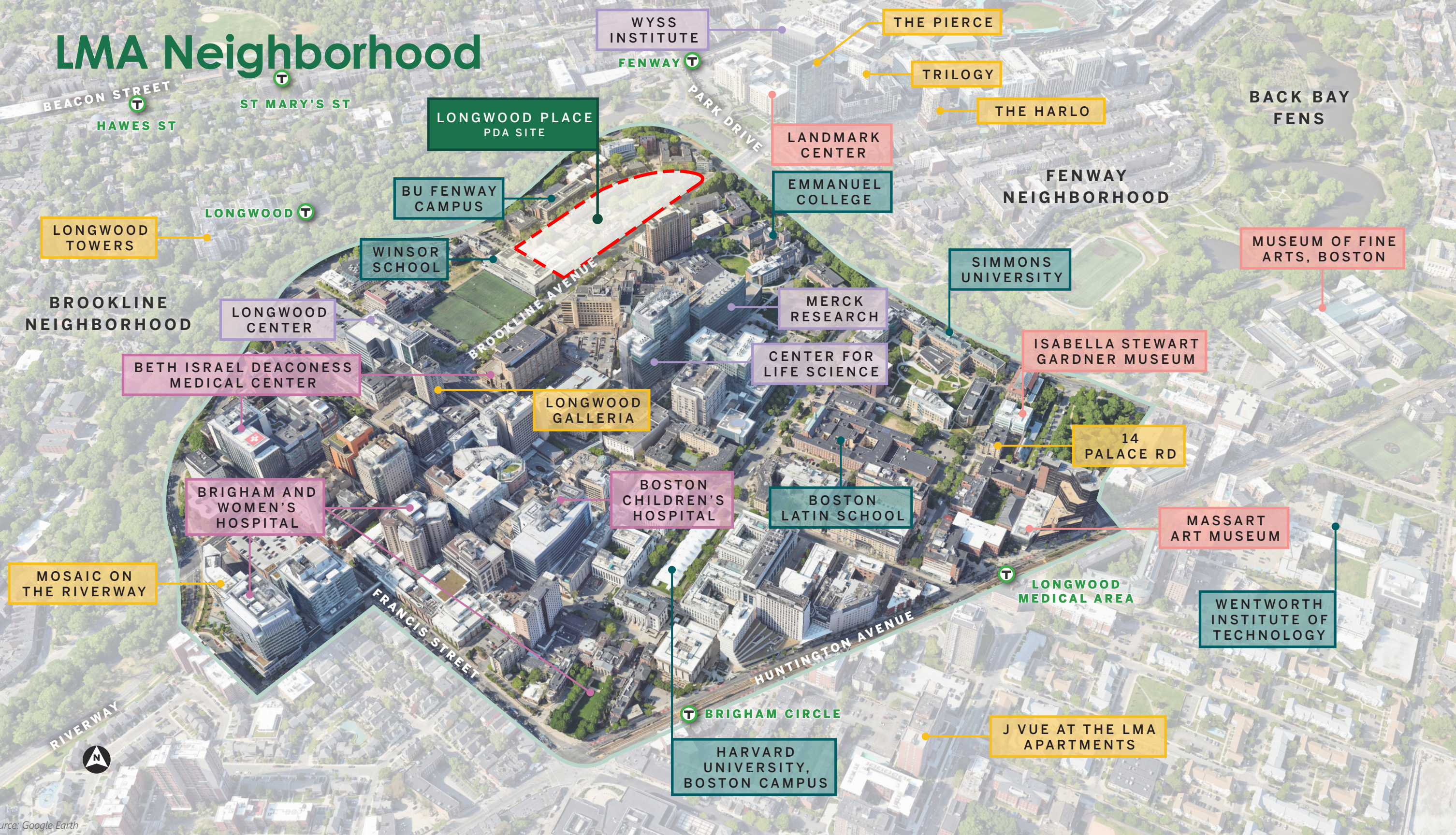

WYSS INSTITUTE
FENWAY T

THE PIERCE

TRILOGY

THE HARLO

BACK BAY FENS

LONGWOOD PLACE
PDA SITE

LANDMARK CENTER

FENWAY NEIGHBORHOOD

BU FENWAY CAMPUS

EMMANUEL COLLEGE

MUSEUM OF FINE ARTS, BOSTON

LONGWOOD TOWERS

LONGWOOD T

WINSOR SCHOOL

SIMMONS UNIVERSITY

BROOKLINE NEIGHBORHOOD

LONGWOOD CENTER

MERCK RESEARCH

BETH ISRAEL DEACONESS MEDICAL CENTER

CENTER FOR LIFE SCIENCE

ISABELLA STEWART GARDNER MUSEUM

LONGWOOD GALLERIA

14 PALACE RD

BRIGHAM AND WOMEN'S HOSPITAL

BOSTON CHILDREN'S HOSPITAL

BOSTON LATIN SCHOOL

MASSART ART MUSEUM

MOSAIC ON THE RIVERWAY

FRANCIS STREET

LONGWOOD MEDICAL AREA T

WENTWORTH INSTITUTE OF TECHNOLOGY



BRIGHAM CIRCLE T

HARVARD UNIVERSITY, BOSTON CAMPUS

J VUE AT THE LMA APARTMENTS

Approved PDA Zoning

PDA APPROVED IN MARCH 2023

- Site Plan with 5 Buildings
- Building Uses
- GFA and Max Floor Plate Sizes
- Heights
- Setbacks
- Parking Spaces
- Public Realm Improvements
- Transportation Improvements

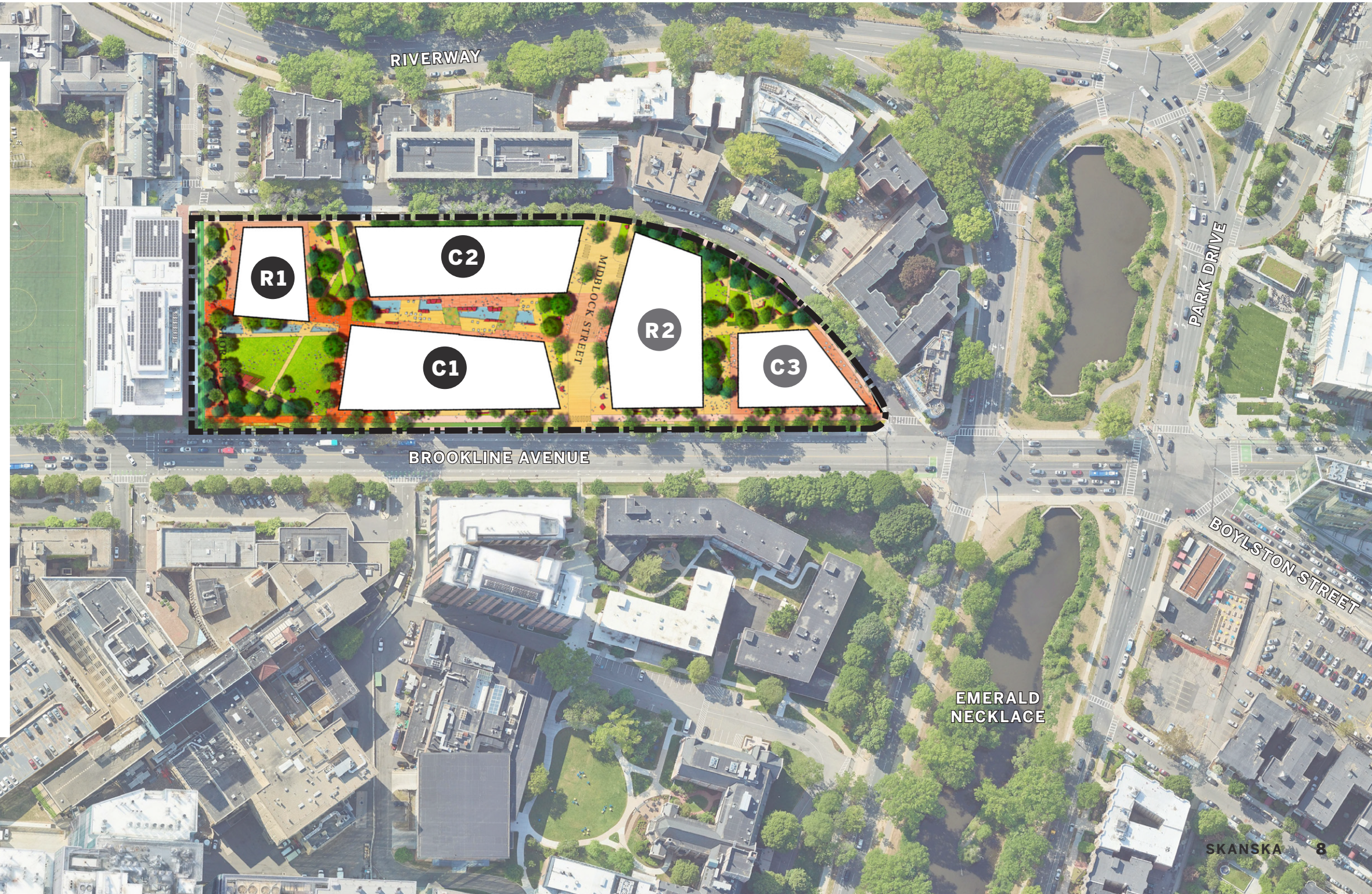

Existing Site Photographs

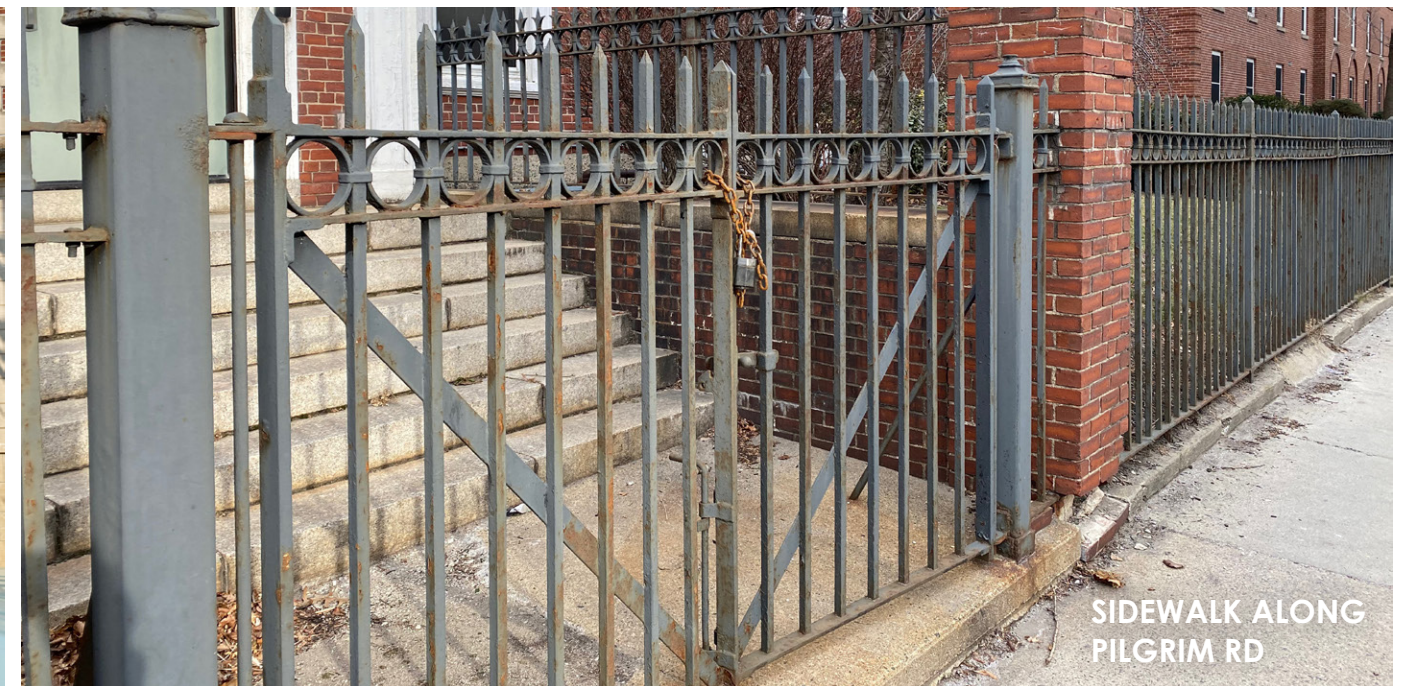

Proposed Project

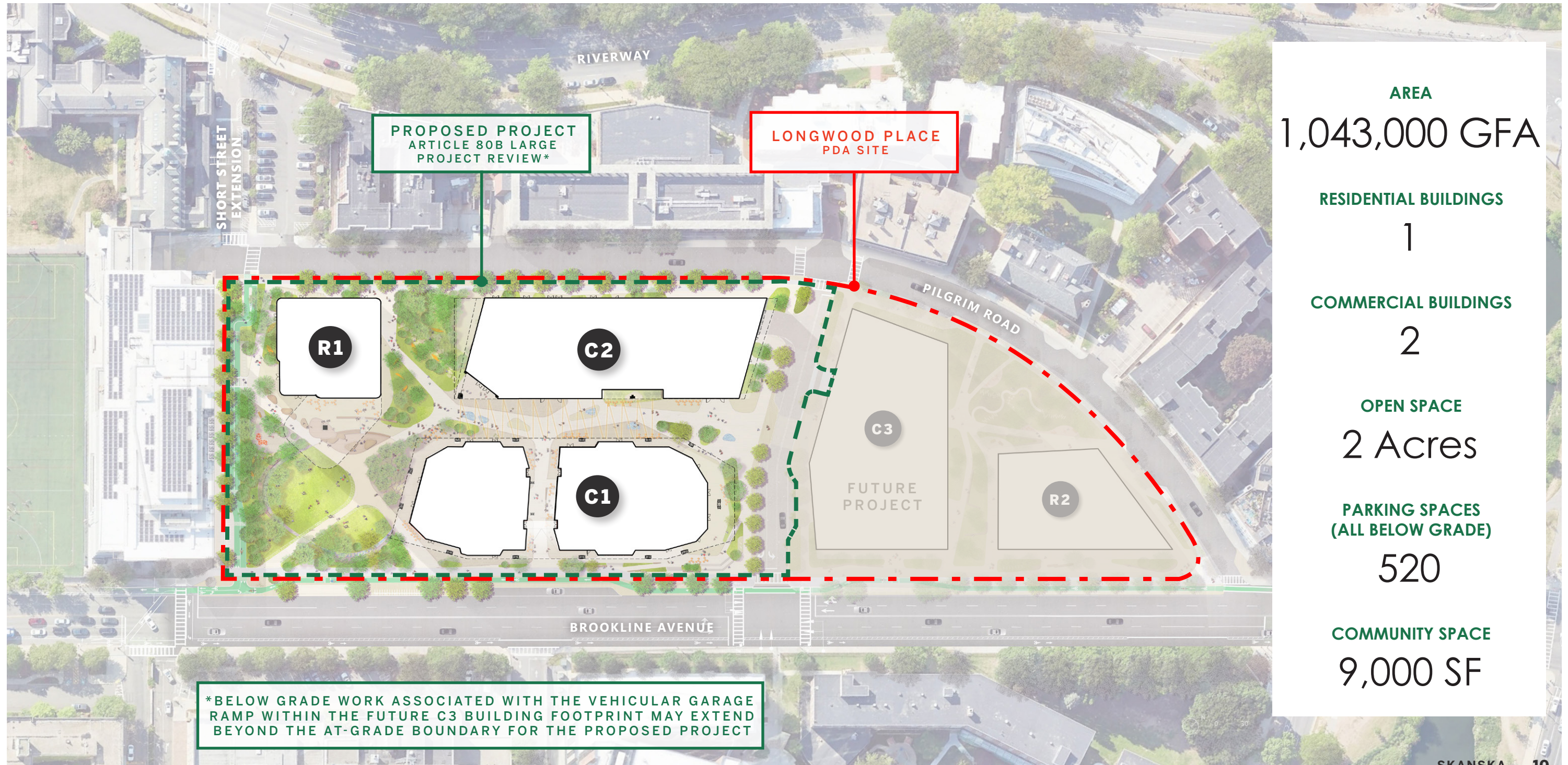

AREA

1,043,000 GFA

RESIDENTIAL BUILDINGS

1

COMMERCIAL BUILDINGS

2

OPEN SPACE

2 Acres

PARKING SPACES (ALL BELOW GRADE)

520

COMMUNITY SPACE

9,000 SF

*BELOW GRADE WORK ASSOCIATED WITH THE VEHICULAR GARAGE RAMP WITHIN THE FUTURE C3 BUILDING FOOTPRINT MAY EXTEND BEYOND THE AT-GRADE BOUNDARY FOR THE PROPOSED PROJECT



2

SID Overview

Feedback Received on the PNF



Design Cohesion & Context Integration



Public Realm & Open Space



Transportation & Site Operations

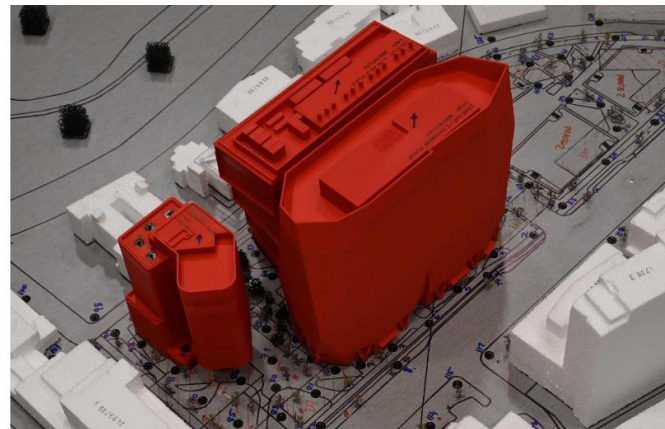

Environmental Design & Impact



Infrastructure, Sustainability & Smart Utilities



Zoning Compliance & Community

Supplemental Information Document (SID) Overview

1. General Information

- Legal information
- Public benefits
- Agency coordination + community process
- Regulatory controls and permits

2. Planning, Zoning & Urban Design

- Zoning compliance and setbacks
- Design evolution and alternatives studied
- Building massing and architectural approach
- Public realm and open space design
- Landscape, materials, and tree plan
- Accessibility and site grading
- Close-up Renderings
- Distanced Renderings

3. Sustainability & Climate Resilience

- Heat island reduction strategies
- Renewable energy (on-site + off-site)
- Embodied carbon reduction

- Advanced energy systems + feasibility studies
- Refrigerant and materials management

4. Environmental Design

- Wind analysis
- Shadow studies and design response
- Solar glare analysis
- Air quality analysis
- Noise analysis

5. Transportation & Mobility

- Traffic and intersection analysis
- Transit and bicycle access
- Future build vs. no-build scenarios
- Area roadway and corridor improvements
- Parking, loading, and curb management
- Transportation Demand Management (TDM)

6. Infrastructure & Smart Utilities

- Stormwater and green infrastructure
- Energy and utility systems
- Smart street lighting and telecom
- EV and smart traffic systems

7. Public & Agency Comments and Responses

- Agency comment letters addressed
- Interagency group input addressed
- Community and stakeholder comments addressed
- Written responses, including project refinements

Shadows as Presented in the SID

- 15 Minute Comparison to the PDA
- Alternative Massing Study
- Reduced Equipment Screen Study

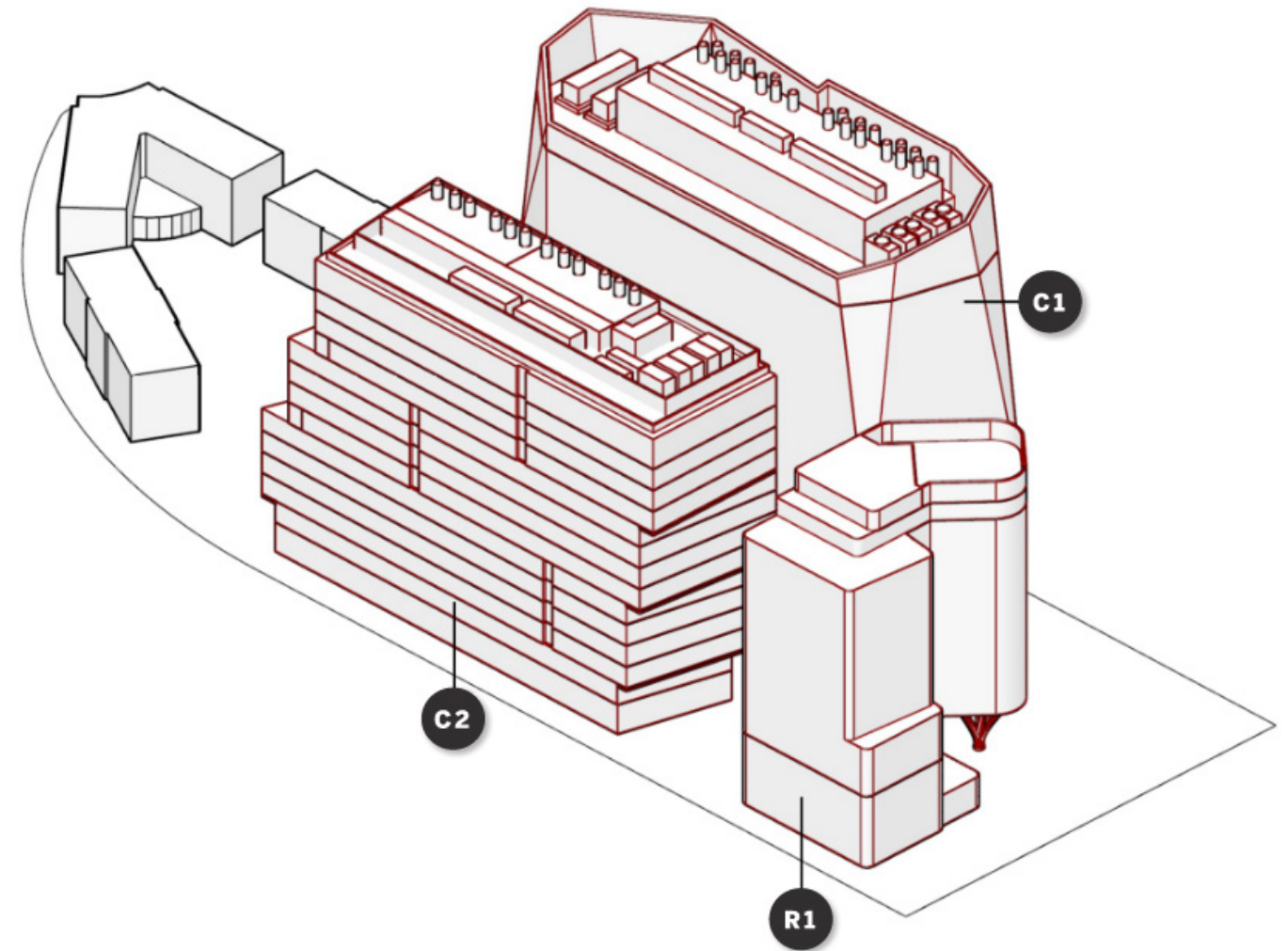

3

Public Realm & Open Space

Landscape Design Principles

'Place to Gather and Heal'

- Longwood Place is a **mixed-use development that integrates public urban park space with three commercial and two residential buildings**, enhancing streetscapes, connectivity and creating a central open space for the LMA.
- **The Main Heart** emerges as an **urban green oasis**, inviting people to rest and contemplate under tree canopies and native ground covers, while a tranquil ribbon of water gracefully meanders from Pilgrim Road celebrating main entrances and enriching the experience.
- Seating areas, water fountains and planted berms **create a journey through the landscape** sometimes directing the view towards the central open space.
- Diverse types of space such as **play space, informal grove and front porch** add to a rich layering of spaces and activities.
- **The Central Connector** is designed as a landscape that prioritizes the pedestrian flows through the site. Lighting, water features, outdoor seating for retail spillout areas, break down the linear corridor to a human scale and active axis.
- At either end of the connector **water features and art installations serve as focal points** drawing people in and marking the main lobbies of adjacent buildings.



*view from Central Connector to Main Heart

Main Heart (PNF)

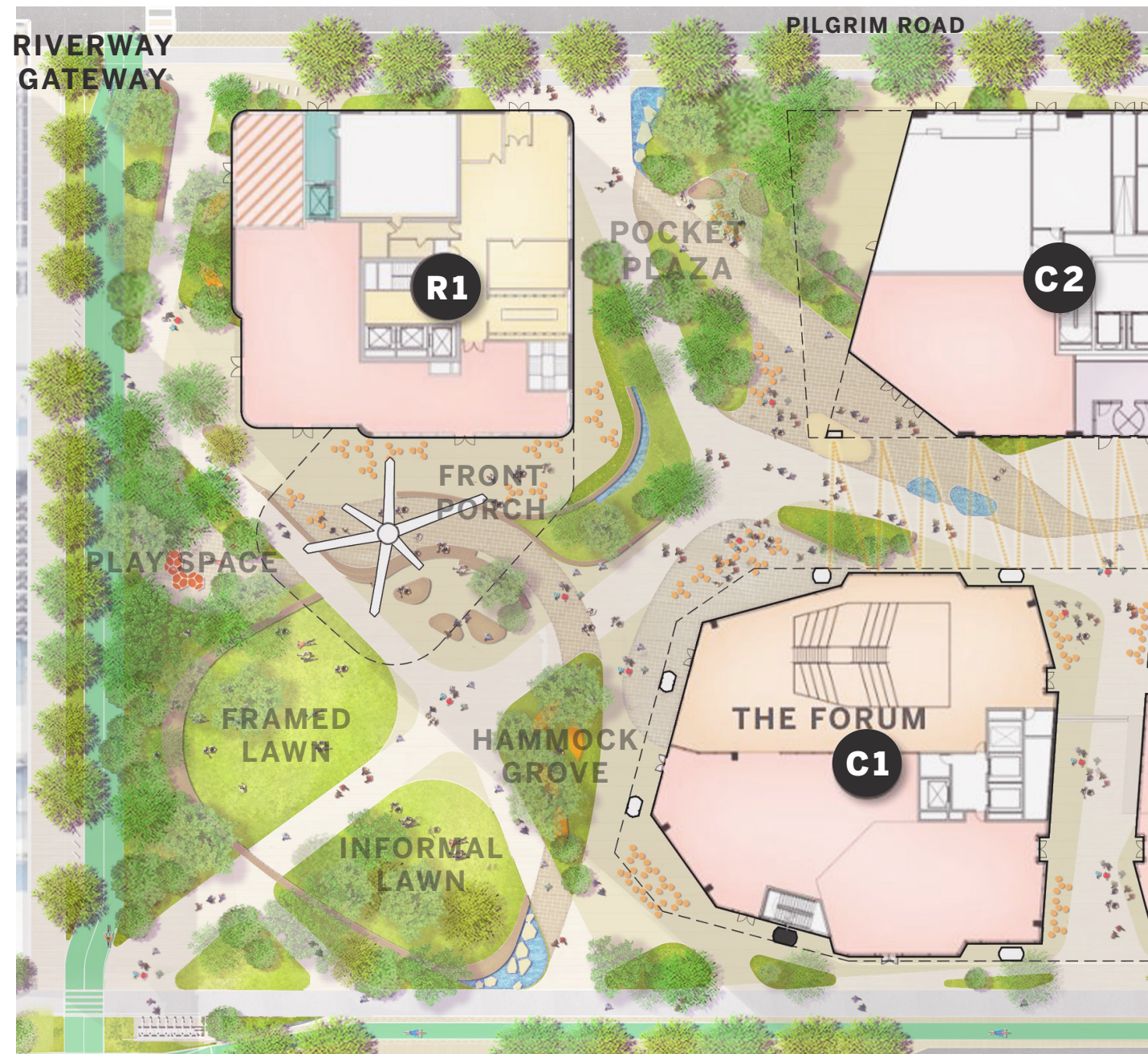

Main Heart (SID-current)

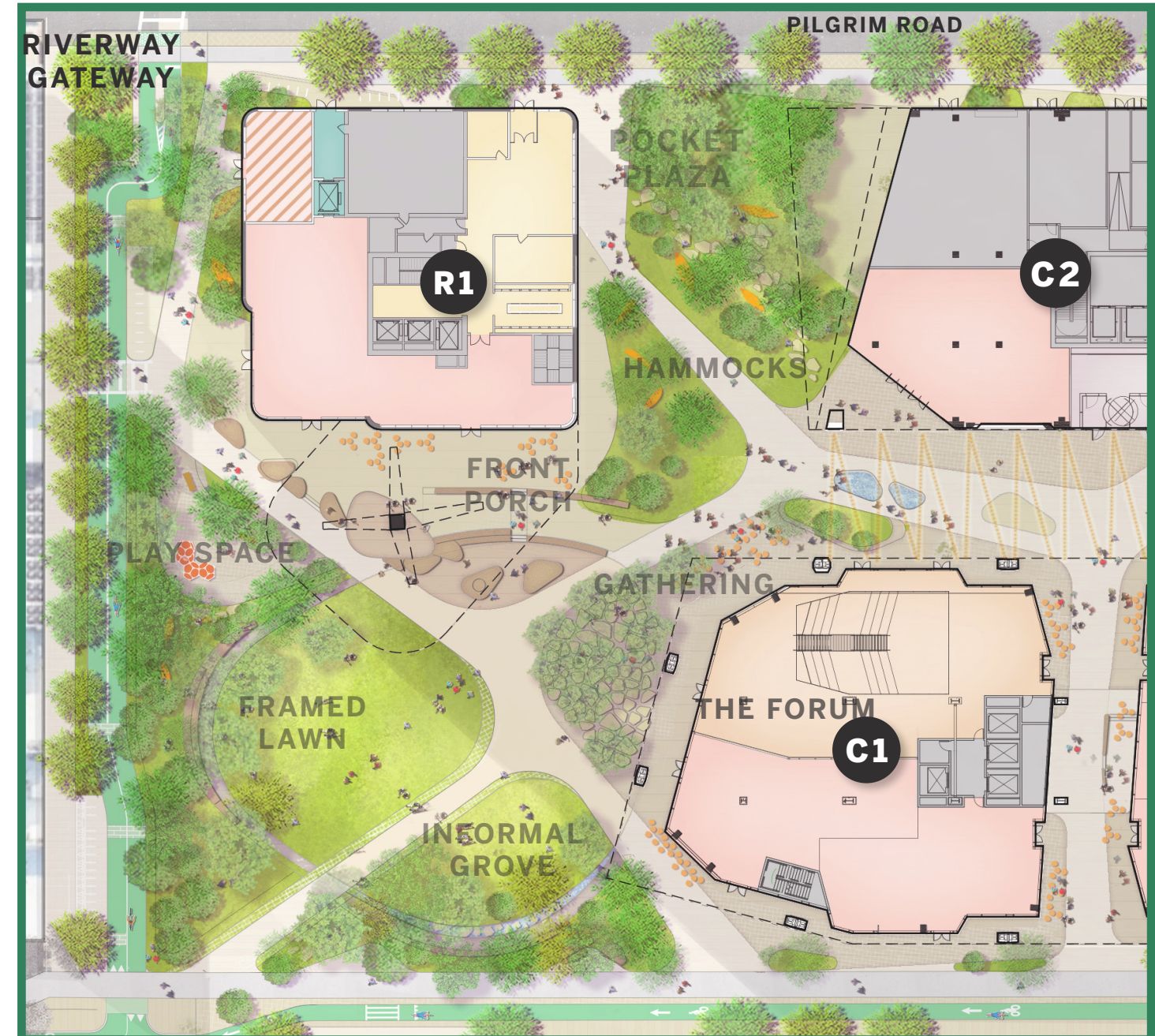

Open Space & Public Realm: SID Plan current

LONGWOOD PLACE
PUBLIC MEETING • MARCH 11, 2026

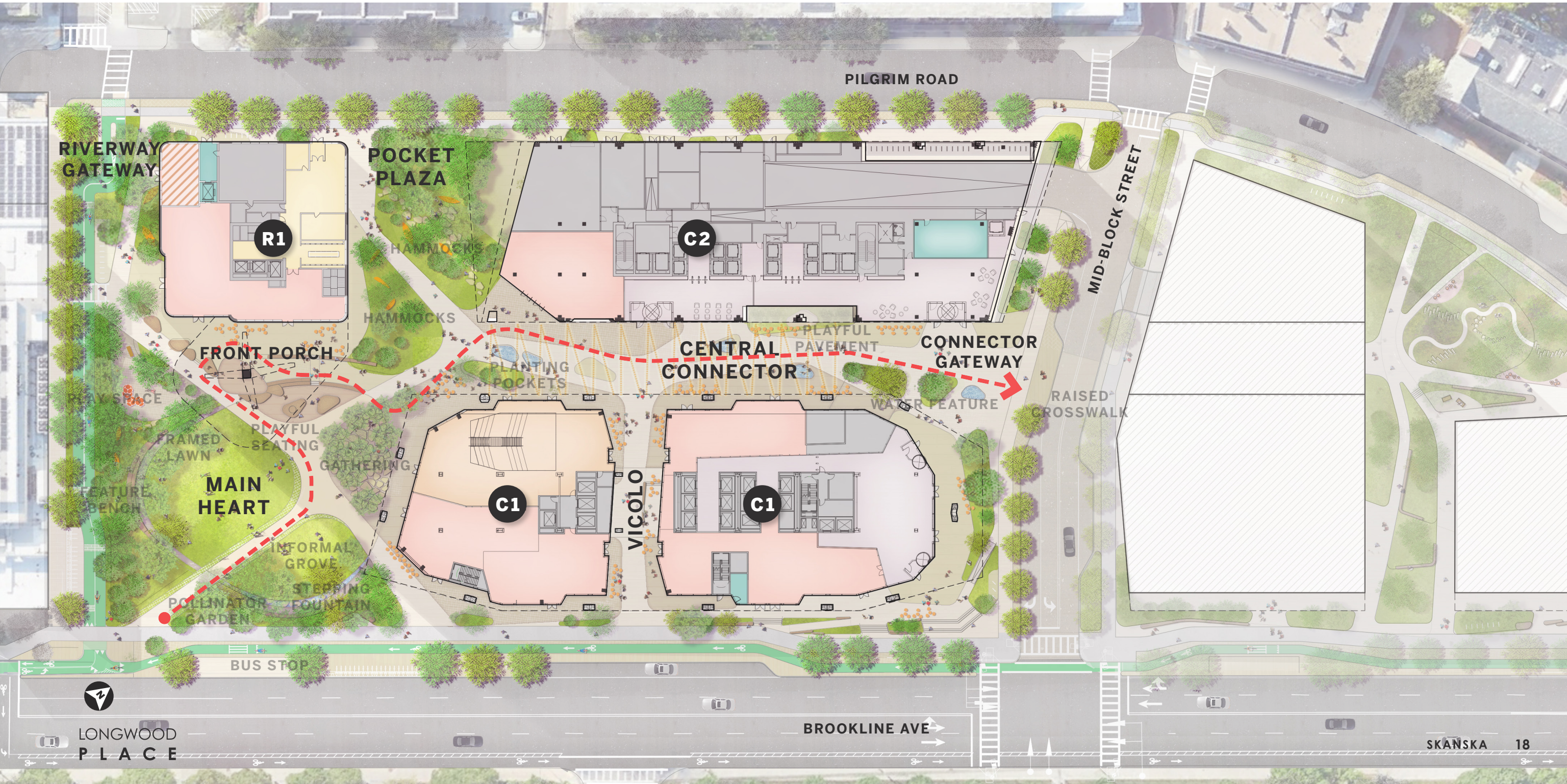

Unifying Elements in the Landscape

Beautifully crafted features that define space throughout the site while creating a variety of seating experiences that brings people together.



FRAMED LAWN



**INFORMAL GROVE AND
WATER FEATURE
NEAR BROOKLINE**

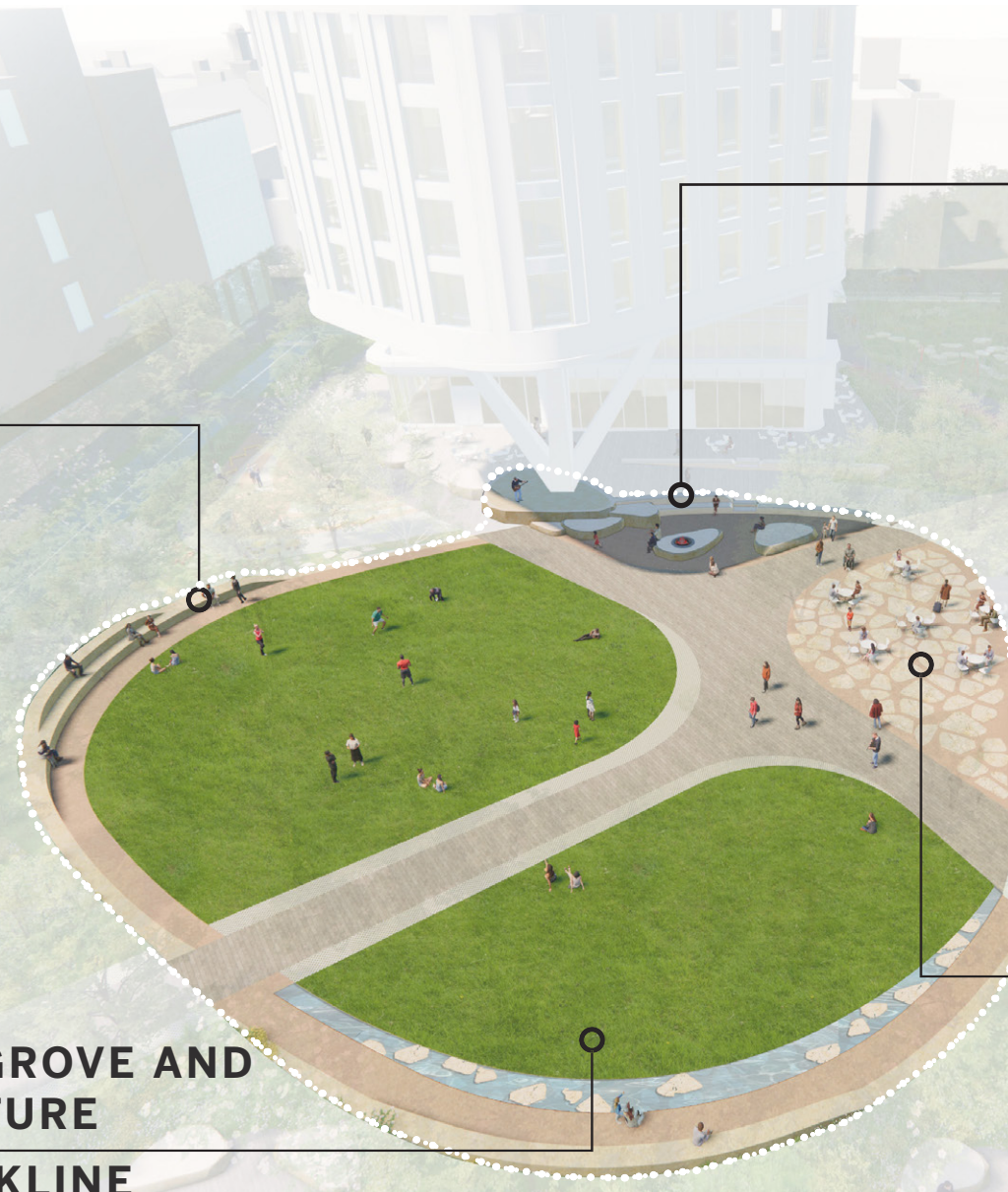

**FRONT PORCH
NEAR R1**



**GATHERING
NEAR C1**



Brookline Avenue

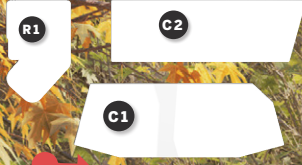

View of Main Heart Brookline Ave

LONGWOOD PLACE
PUBLIC MEETING • MARCH 11 2026



Framed Lawn at Main Heart



Front Porch

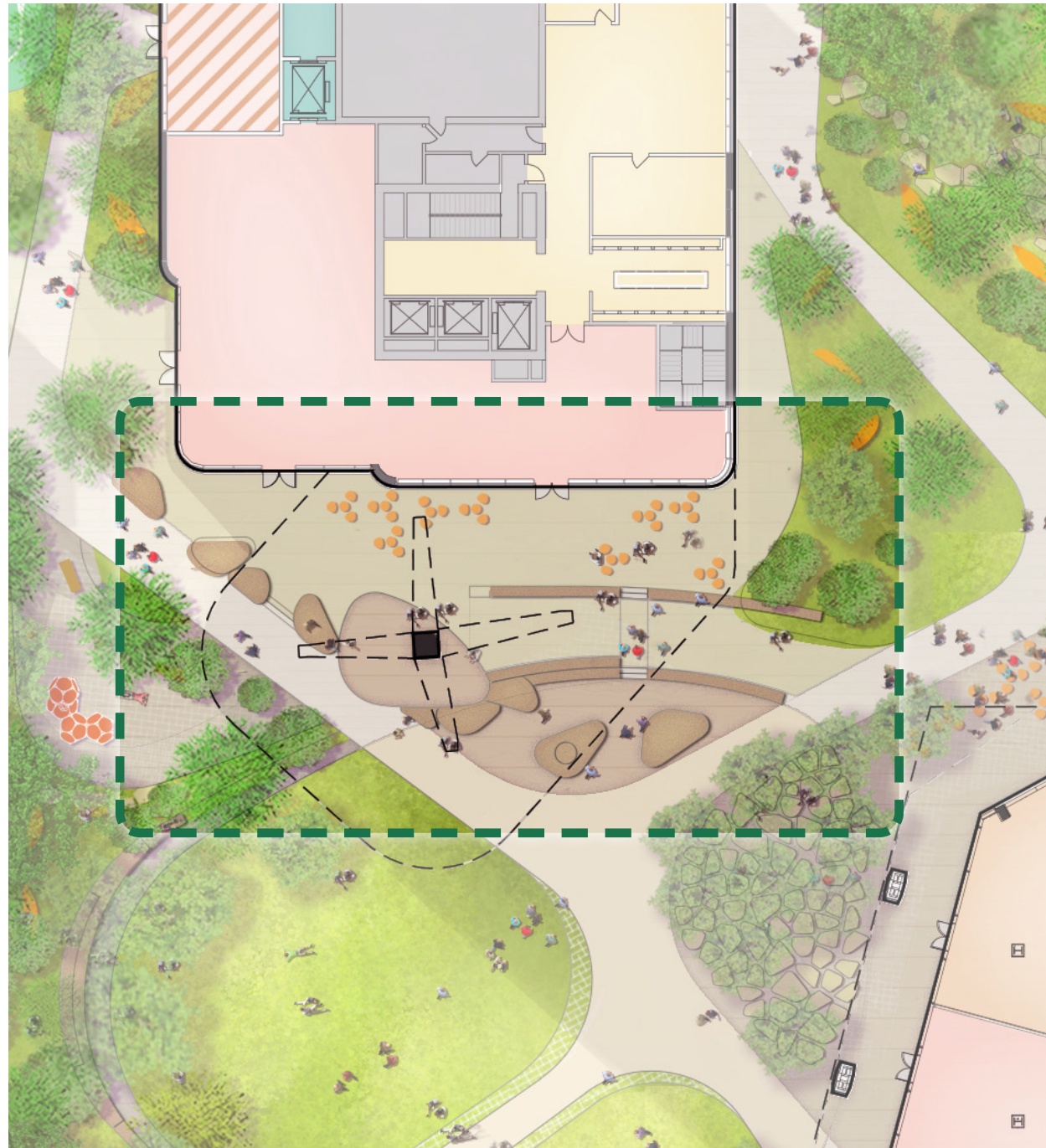

Front Porch

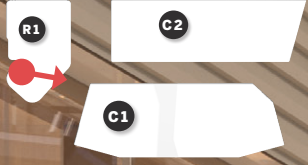

View of Main Heart from Front Porch

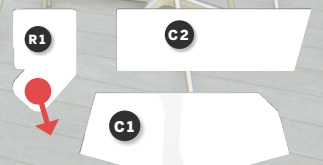
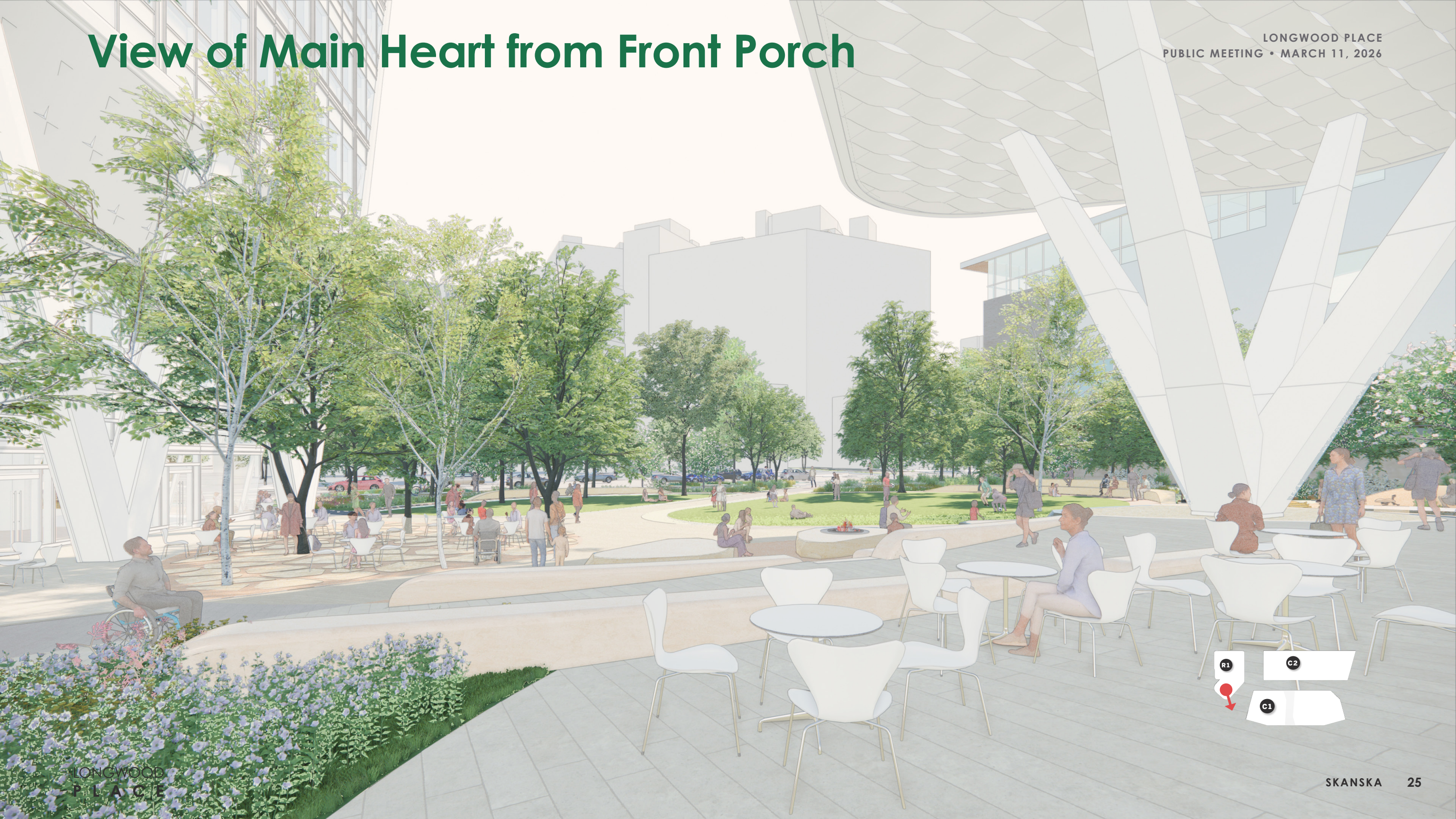

View of the Gathering under the Grove



View of the Hammock lounge

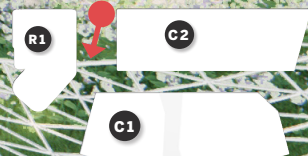

Central Connector



4

Building Design

Unifying Building Design Principles

3

Create an invitation into the site with deliberate architectural form.

4

Develop a harmonious composition of buildings with architecture that responds to its context and programmatic functions.

2

Extend the public realm by lifting the building bases above the ground plane.

1

Create a network of open spaces that is a respite from the intensity of the LMA.

Design Progression

C1

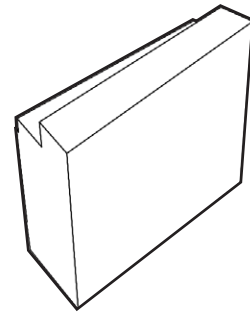

C2

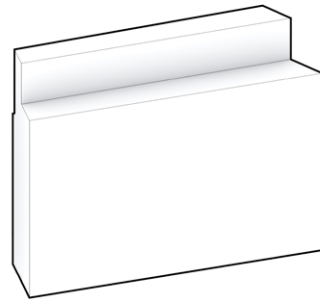

R1

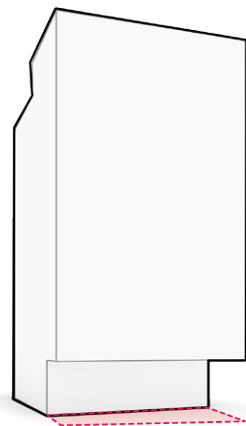

Design Progression

PNF



SID



BUILDING DESIGN

Building C1

Site Plan

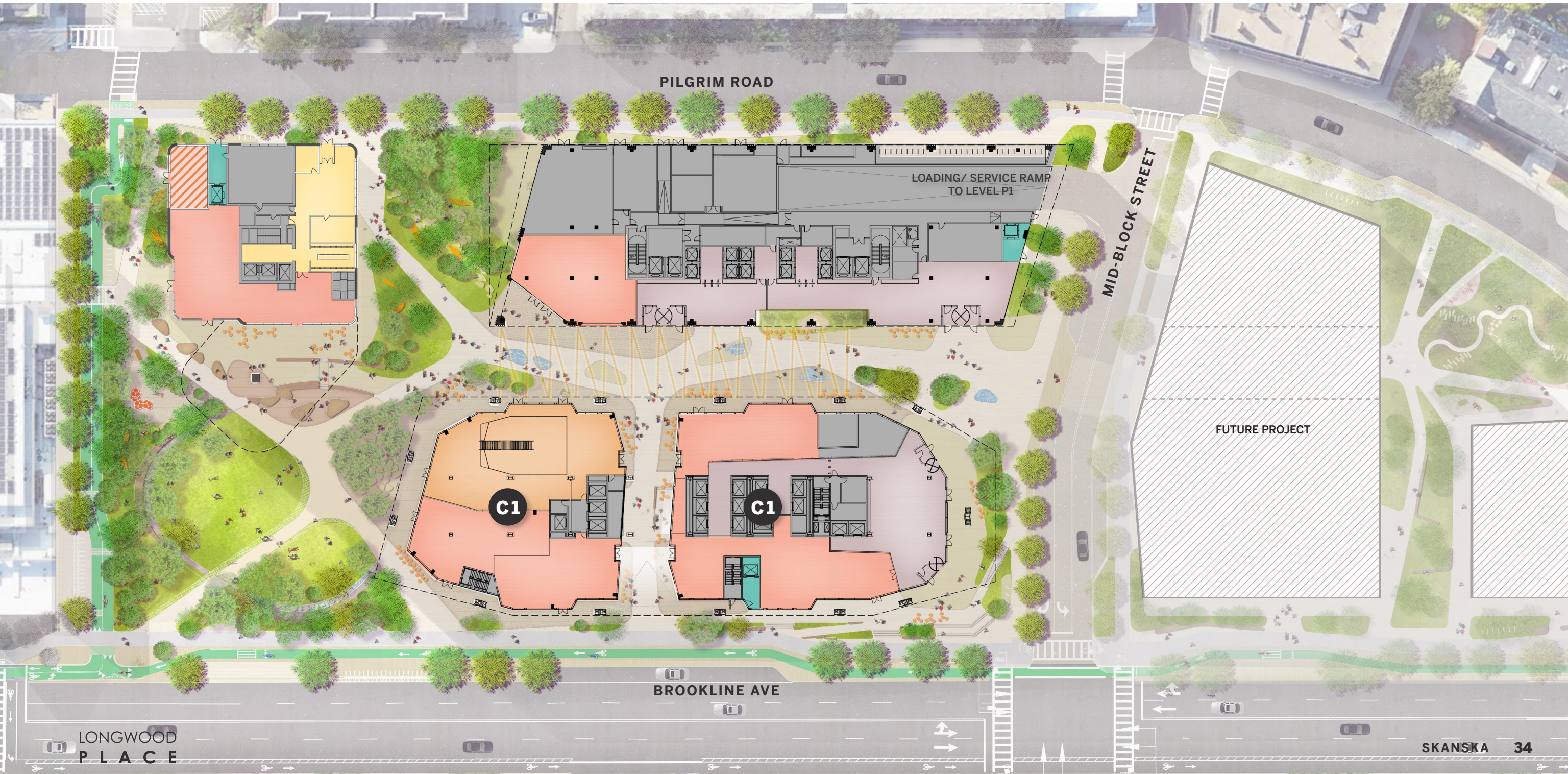

PILGRIM ROAD

LOADING/ SERVICE RAMP
TO LEVEL P1

MID-BLOCK STREET

FUTURE PROJECT

C1

C1

BROOKLINE AVE

LONGWOOD
PLACE

SKANSKA 34

C1 Building Design



PNF



SID

C1 Building Design: SID

R1

C2

C1

LONGWOOD
PLACE

C1 Building Design



PNF



SID

C1 Building Design: SID - Pedestrian Experience

LONGWOOD PLACE
PUBLIC MEETING • MARCH 11, 2026

R1

C2

C1



C1 Building Design: SID - Pedestrian Experience

LONGWOOD PLACE
PUBLIC MEETING • MARCH 11, 2026

R1

C2

C1



BUILDING DESIGN

Building C2

Site Plan

LONGWOOD PLACE
PUBLIC MEETING • MARCH 11, 2026

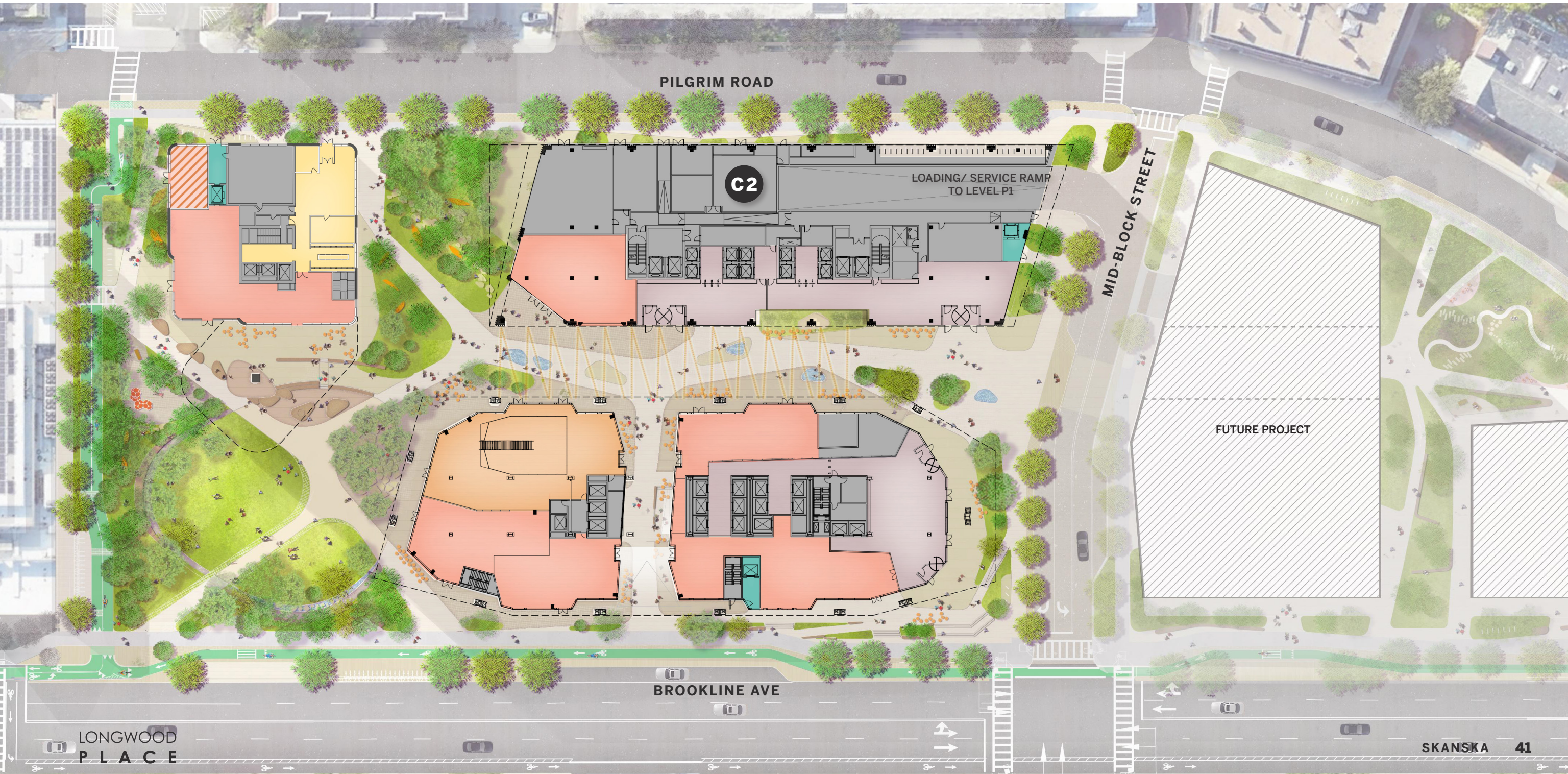

C2 Building Design



C2 Building Design : View from Vicolo

R1

C2

C1

M Health

MOMO HEALTH

BREW LAB

C2 Building Design: Central Connector

R1

C2

C1

C2 Building Design: Pilgrim Road

R1

C2

C1

C2 Building Design: PNF - View from Riverway

R1

C2

C1

C2 Building Design: SID - View from Riverway

R1

C2

C1



BUILDING DESIGN

Building R1

Site Plan

LONGWOOD PLACE
PUBLIC MEETING • MARCH 11, 2026



R1 Building Design



PNF



SID

R1 Building Design: PNF

R1

C2

C1

R1 Building Design: SID

R1

C2

C1



R1 Building Design: SID View from the Riverway

LONGWOOD PLACE
PUBLIC MEETING • MARCH 11, 2026

R1

C2

C1



R1 Building Design: SID

R1

C2

C1

Longwood

5

Summary of Public Benefits

Vehicular Improvements

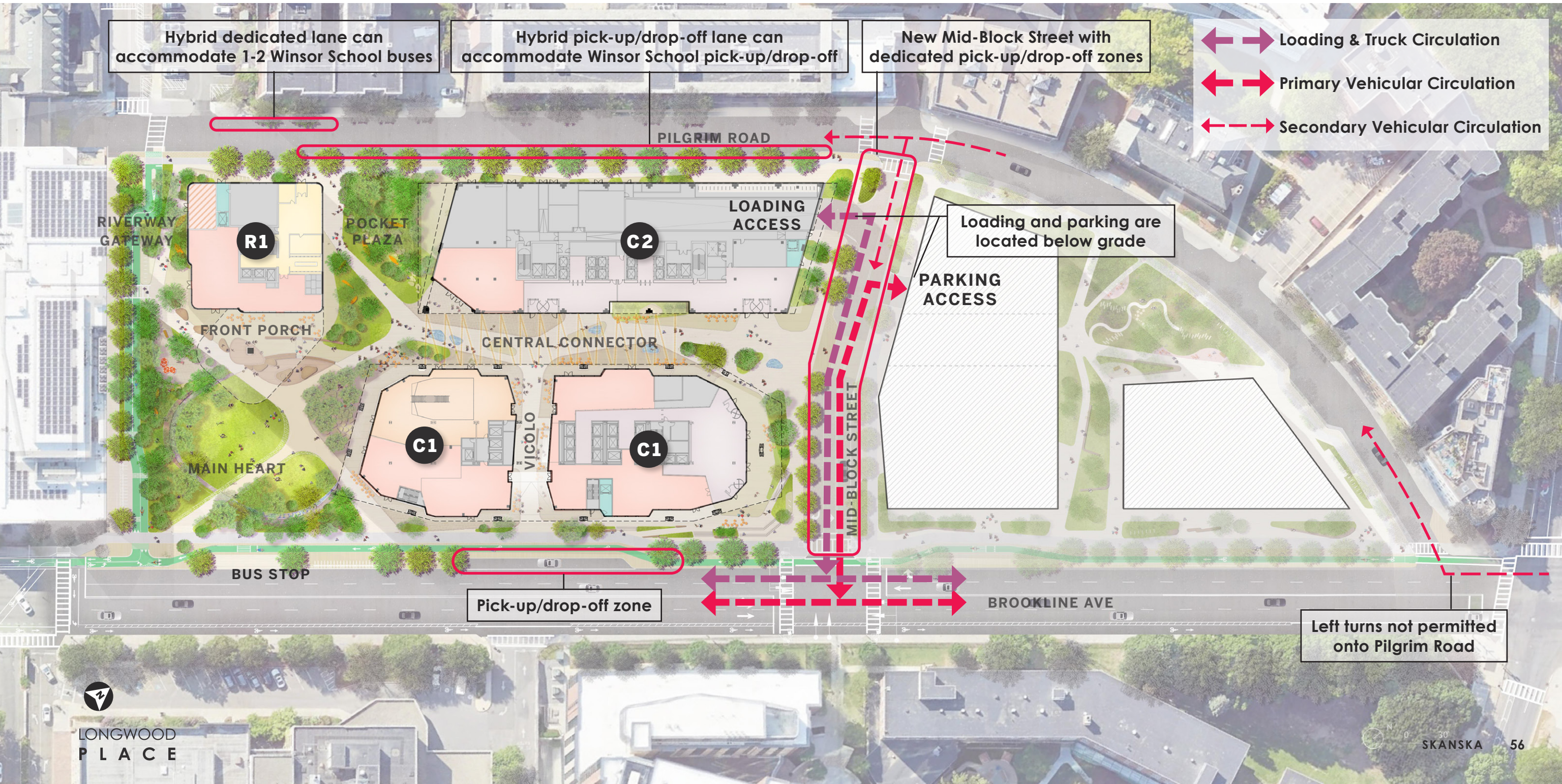

Hybrid dedicated lane can accommodate 1-2 Winsor School buses

Hybrid pick-up/drop-off lane can accommodate Winsor School pick-up/drop-off

New Mid-Block Street with dedicated pick-up/drop-off zones

- ↔ Loading & Truck Circulation
- ↔ Primary Vehicular Circulation
- ↔ Secondary Vehicular Circulation

Loading and parking are located below grade

Left turns not permitted onto Pilgrim Road

Pedestrian & Bicycle Improvements

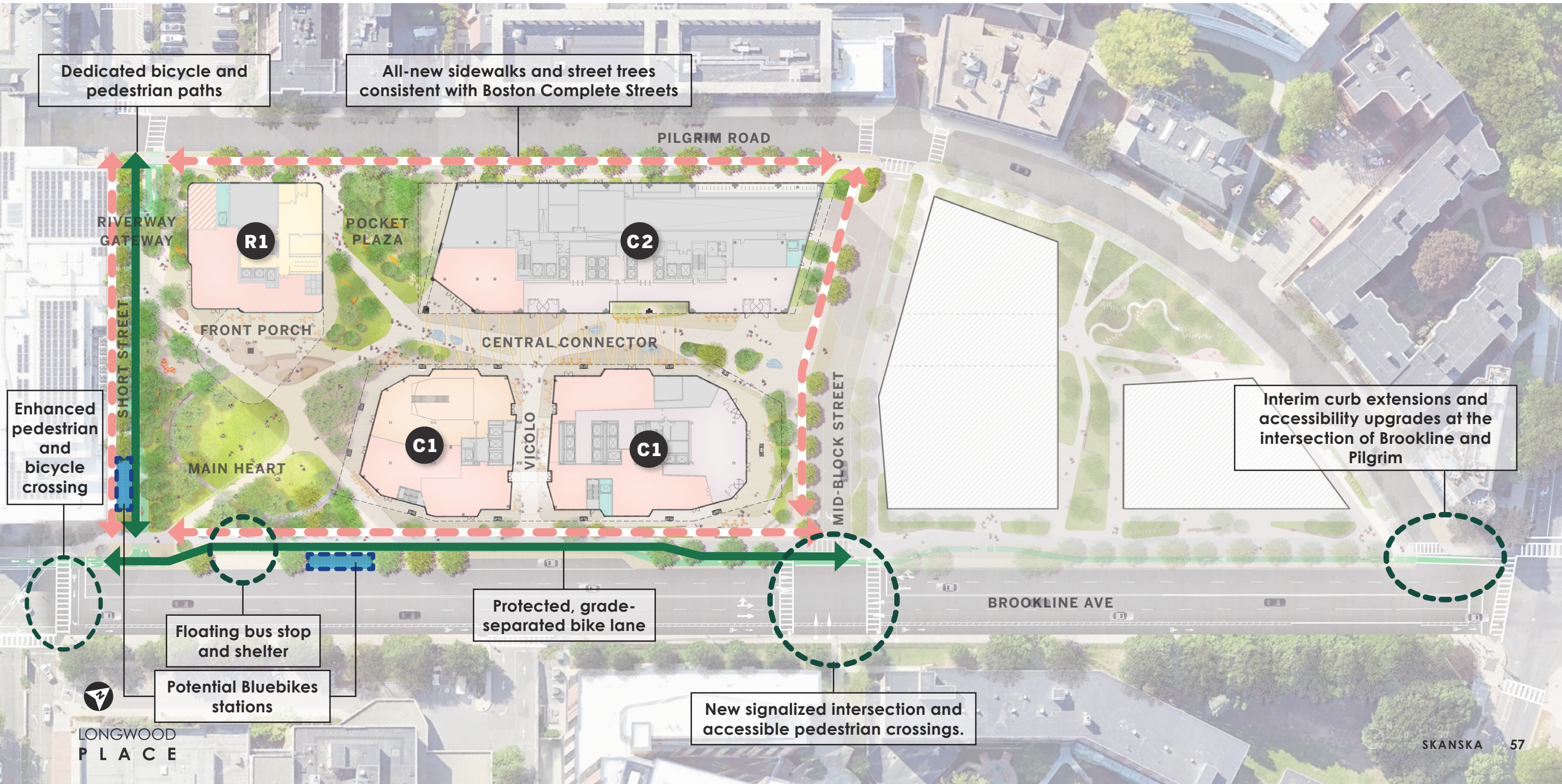

Dedicated bicycle and pedestrian paths

All-new sidewalks and street trees consistent with Boston Complete Streets

PILGRIM ROAD

RIVERWAY GATEWAY

R1

POCKET PLAZA

C2

FRONT PORCH

CENTRAL CONNECTOR

MAIN HEART

C1

VICOLO

C1

MID-BLOCK STREET

Interim curb extensions and accessibility upgrades at the intersection of Brookline and Pilgrim

Enhanced pedestrian and bicycle crossing

SHORT STREET

Protected, grade-separated bike lane

BROOKLINE AVE

Floating bus stop and shelter

Potential Bluebikes stations

New signaled intersection and accessible pedestrian crossings.

Sustainability & Resiliency Benefits

Residential Building (R1)

- LEED v4 Gold Certifiable
- Passive House Certifiable
- **All Electric** Building

Site/Landscape

- Grey and **green infrastructure** systems to manage and retain **1.25 inches** of rainfall on-site
- **2.0 Acres** of publicly accessible **open space & public realm**
- Native and adopted landscape design to support **habitat biodiversity**
- **Robust tree canopy** to reduce heat island effect
- **Dedicated bike lanes** and sidewalks to encourage **alternative transportation**
- **Elevated** or **protected** electrical vaults

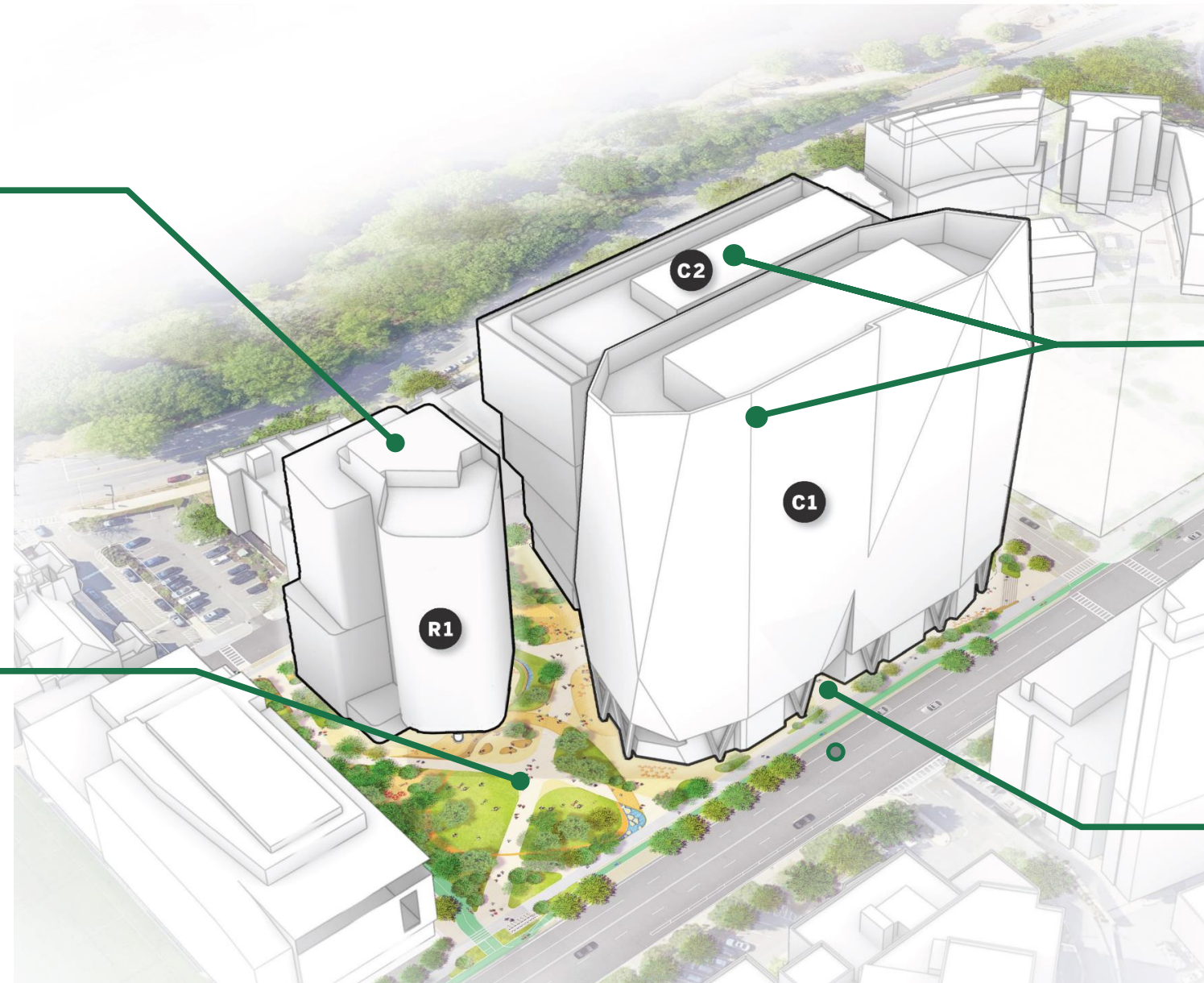

Commercial Buildings C1 & C2

- LEED v4 Gold Certifiable
- High-performance building envelope
- Advanced Heat Pump system for **25% Electrification**, designed for **future 100% electrification**

Garage & Loading Dock

- **Below-grade loading** and parking to prioritize the **public realm** and **reduce heat island** effect
- **25%** of parking spaces with **EV charging**, remaining **75% EV ready**

Urban Design & Public Realm Benefits

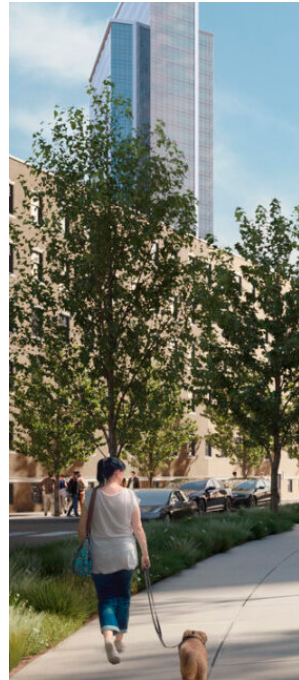

- Approximately **2.0 acres** of open space and public realm
- Variety of **passive and active open spaces**, with a mix of plantings, lawn, playful zones and pedestrian connectivity.
- **9,000 sf community space** and public programming
- Activated ground floor with **food and beverage** offerings
- **Replace dead/dying trees** along Pilgrim Road
- **Below-grade** parking, service and loading

The Forum



Community Benefits



- **±227 New Rental Units** (20 percent affordable)
- **\$7M endowment** to Boston Parks
- **±\$11.8M** in Linkage Fees (\$10M housing/\$1.8M Jobs)
- **±3,000** Permanent Jobs/**±3,000** Construction Jobs
- Diverse **new retail offerings** including food and beverage options
- Permanent and rotating/short-term **art installations** by a **diverse range of artists**

Thank you